

Installation

Study this guide carefully before proceeding. Failure to observe the warnings and instructions given may cause a malfunction or personal hazard.

- 1 CHECK the environment. See Q
- 2 INSTALL the ACS 100. See A, B
- 3 REMOVE the cover. See C
- 4 USE a warning sticker with the language of your choice. See E
- 5 IDENTIFY power and control terminals. See D, E, G
- 6 CHECK voltage supply. See F
- 7 CHECK the motor. See H
- 8 SET configuration switch S1. See I
- 9 CONNECT power terminals. See D, E
- 10 CONNECT control wires. See E, G, J
- 11 REPLACE the cover. See K
- 12 TURN the power on. See L

A Dimensions (mm)

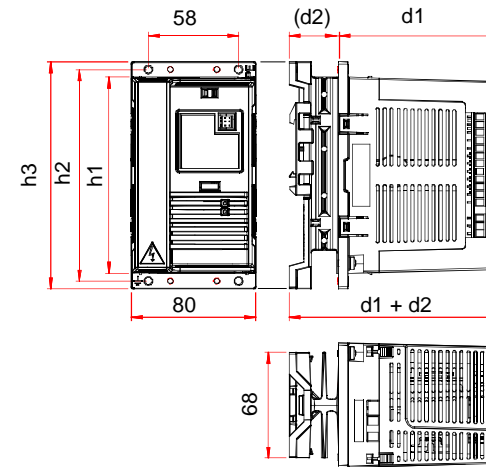

Frame Size IP 20							Weight (kg)	
	h1	h2	h3	d1	(d2)	d1+d2	1~	3~
A	126	136	146	106	32	138	0.9	0.8
B	126	136	146	106	69	175	1.2	1.1
C	198	208	218	106	104	210	2.2	2.0
D	225	235	245	113	115	228	2.7	2.5

B Installing the ACS 100

Install the ACS 100 vertically. Leave 25 mm free space above and below the unit. Ensure that there is sufficient cool air in the cabinet to compensate for the power losses listed at the end of section P, Technical Data.

Wall-mounting

Use M4 screws.

DIN rail (35 mm)

Press the lever on top of the unit while installing on / removing from DIN rail.

Flange-mounting

The ACS 100 can be installed so that the heat sink is in the air duct. The power circuit losses will then be dissipated outside leaving only the control circuit losses to be dissipated inside (see P).

C Removing the Cover

Press the four snap-on buttons in the top and bottom corners of the unit simultaneously.



Warning! Turn power off and wait 5 minutes before removing cover.

D Cable Connections

Terminal	Description	Note
L, N	1~ power supply input	In figure below (see E), a 3~ unit is shown.
U1, V1, W1	3~ power supply input	Do not use in 1~ supply!
PE	Protective Earth	Min. 4 mm ² Cu wire
U2, V2, W2	Power output to motor	Max. cable length 75 m without output choke.
Uc+, Uc-	DC bus voltage 325 V	Do not connect!
	Motor cable shield	

Follow local rules for cable cross-sections. Use shielded motor cable. Route the motor cable away from control wires and power supply cable to avoid electromagnetic interference.



Note! See ACS 100 EMC instructions.

E Terminal Interface

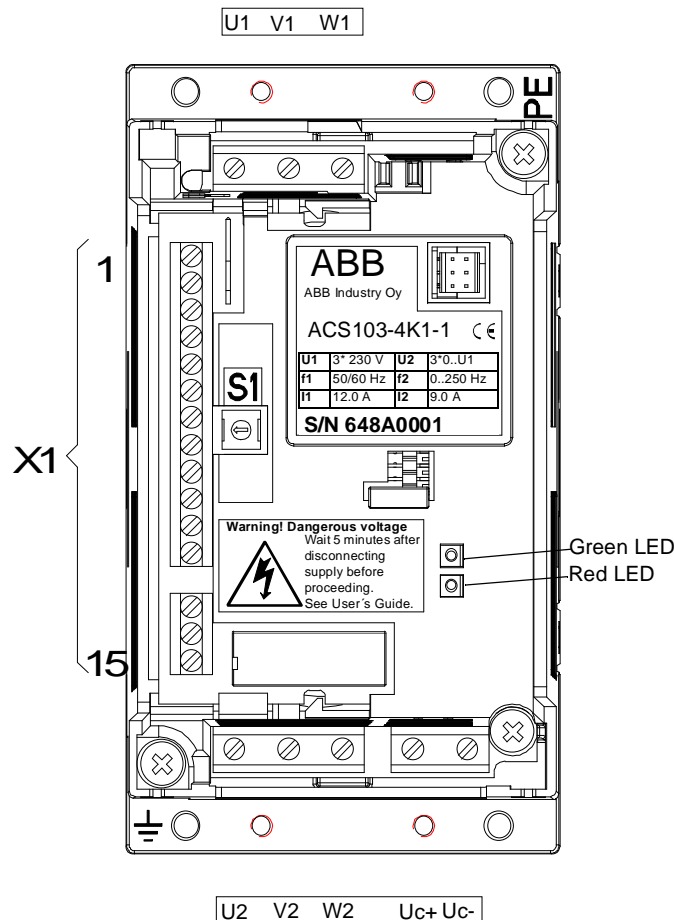

F Type Designation Label and Code Key

Supply:
ACS 101 = 1 ~
ACS 103 = 3 ~

Power:
4K1 = 4.1 kVA

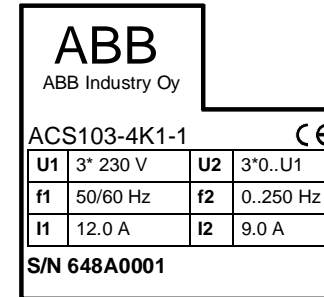

Serial number:
S/N 648A0001
6 = Year
48 = Week
A0001= Internal number

G Control Terminals

X1	Identification	Description				
1	SCR	Terminal for signal cable screen. (Connected internally to frame earth.)				
2	AI	Analogue input 0-10 V \Leftrightarrow 0- f_{nom} output frequency. $R_i = 190 \text{ k}\Omega$ (0-10 V signal) / 500 Ω (0-20 mA signal). Resolution 0.1 % accuracy ± 1 %.				
3	AGND	Analogue input circuit common. (Connected internally to frame earth through 1 M Ω)				
4	10 V	10 V reference voltage output for analogue input potentiometer, accuracy ± 2 %, 10 mA.				
5	All	Analogue input AI can be configured to accept 0- 20 mA signal by shorting terminals 5 and 6. Then $R_i = 500 \Omega$.				
6	AGND	Terminals for DI return wires.				
7	AGND					
8	12 V	Aux. voltage output 12 V DC. $I_{max} = 100 \text{ mA}$ (reference to AGND). Short circuit protected.				
9	DCOM	Digital input common. To activate a digital input, there must be +12 V (or -12 V) between that input and DCOM. The 12 V may be provided by the ACS 100 (X1:8) as in the connection examples (see J) or from an external 12-24 V source of either polarity.				
DI Configuration		<table border="1"> <thead> <tr> <th>ABB Standard</th> <th>3-wire</th> </tr> </thead> <tbody> <tr> <td>($f_{nom} = 50 \text{ Hz}$) $S1 = \{0;1;2;3;4\}$. See I</td> <td>($f_{nom} = 60 \text{ Hz}$) $S1 = \{5;6;7;8;9\}$. See I</td> </tr> </tbody> </table>	ABB Standard	3-wire	($f_{nom} = 50 \text{ Hz}$) $S1 = \{0;1;2;3;4\}$. See I	($f_{nom} = 60 \text{ Hz}$) $S1 = \{5;6;7;8;9\}$. See I
ABB Standard	3-wire					
($f_{nom} = 50 \text{ Hz}$) $S1 = \{0;1;2;3;4\}$. See I	($f_{nom} = 60 \text{ Hz}$) $S1 = \{5;6;7;8;9\}$. See I					
10	DI 1	<table border="1"> <tbody> <tr> <td>Start. Activate to start. Motor will ramp up to frequency reference. Disconnect to stop. Motor will coast to stop.</td> <td>Start. If DI 2 is activated, momentary activation of DI 1 starts the ACS 100.</td> </tr> </tbody> </table>	Start. Activate to start. Motor will ramp up to frequency reference. Disconnect to stop. Motor will coast to stop.	Start. If DI 2 is activated, momentary activation of DI 1 starts the ACS 100.		
Start. Activate to start. Motor will ramp up to frequency reference. Disconnect to stop. Motor will coast to stop.	Start. If DI 2 is activated, momentary activation of DI 1 starts the ACS 100.					
11	DI 2	<table border="1"> <tbody> <tr> <td>Reverse. Activate to reverse rotation direction.</td> <td>Stop. Momentary inactivation always stops the ACS 100.</td> </tr> </tbody> </table>	Reverse. Activate to reverse rotation direction.	Stop. Momentary inactivation always stops the ACS 100.		
Reverse. Activate to reverse rotation direction.	Stop. Momentary inactivation always stops the ACS 100.					
12	DI 3	<table border="1"> <tbody> <tr> <td>Jog. Activate to set output frequency to constant 5 Hz.</td> <td>Reverse. Activate to reverse rotation direction.</td> </tr> </tbody> </table>	Jog. Activate to set output frequency to constant 5 Hz.	Reverse. Activate to reverse rotation direction.		
Jog. Activate to set output frequency to constant 5 Hz.	Reverse. Activate to reverse rotation direction.					
13	RO 1	<p>Fault relay output. Fault: RO 1 and RO 2 connected. 12 V-250 V AC / 30 V DC 10 mA - 2 A</p>				
14	RO 2					
15	RO 3					

Digital input impedance 1.5 k Ω .
Use multi-strand 0.5-1.5 mm² wire.

Note! For fail safe reasons the fault relay signals a "fault", when the ACS 100 is powered down.

H Motor

Check that the motor is compatible. The motor must be a three-phase induction motor, with U_N from 200 to 240 V and f_N either 50 Hz or 60 Hz. The motor nominal current, I_N , must be less than the nominal output current of the ACS 100, I_2 (See **F** and **P**).

I Configuration Switch

The position of the configuration switch S1 determines:

- the nominal frequency f_{nom} (set to motor f_N)
- the acceleration and deceleration ramp time
- the I/O configuration of digital inputs (See **J**)

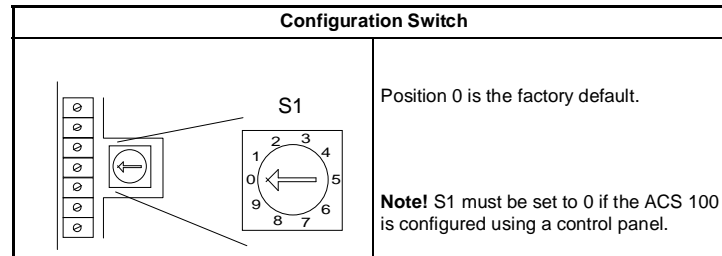

When setting the position of S1, first ascertain the motor nominal frequency f_N and then select the desired ramp time.

The configuration of digital inputs (DI) is dependent on the nominal frequency f_{nom} .

f_{nom}	Ramp Time 0 - f_{nom}	S1-position	DI Configuration
50 Hz	5 s	0	ABB standard
	1 s	1	
	10 s	2	
	30 s	3	
	60 s	4	
60 Hz	1 s	5	3-wire
	5 s	6	
	10 s	7	
	30 s	8	
	60 s	9	

Note! The ACS 100 reads the position of the configuration switch during power up. Never set S1 when the ACS 100 is powered on.

J Connection Examples

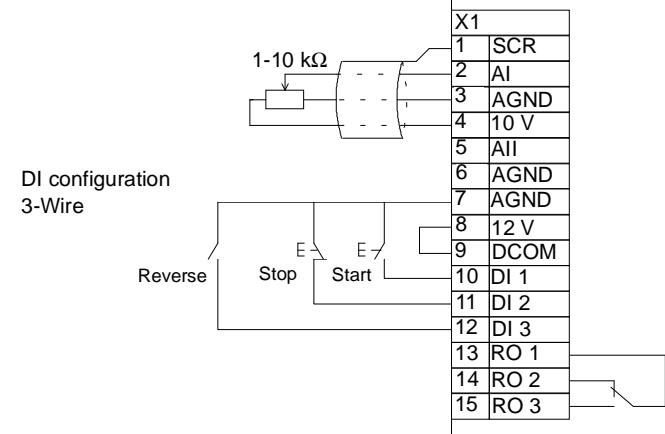
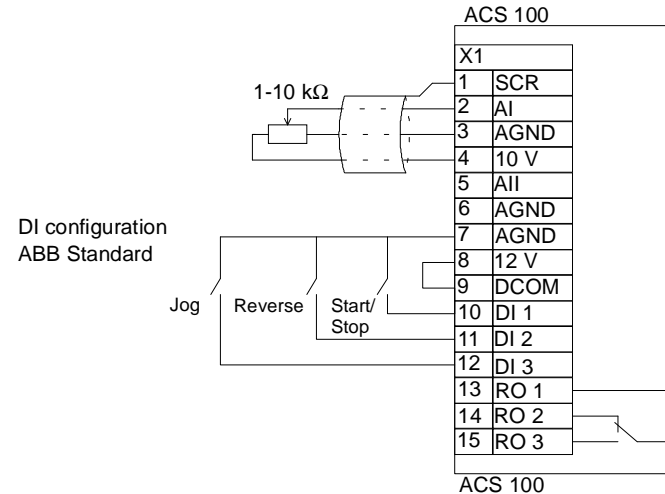

Frequency Reference from a Current Source

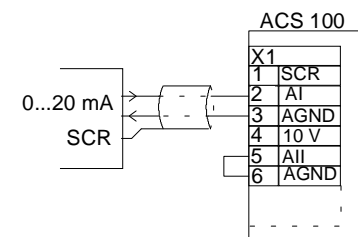

K Replace the Cover

Do not turn the power on before snapping the cover back on.

L Power On

When power is supplied to the ACS 100, the green LED comes on.

M Protection Features

The ACS 100 has a number of protective features:

- Overcurrent
- Overvoltage
- Undervoltage
- Overtemperature
- Output earth fault
- Output short circuit
- Input phase loss (3~)
- Power loss ride through (500 ms)
- I/O terminal short circuit
- Long-term overcurrent limit trip 110 %
- Short-term current limit 150 %
- Motor overload protection (see N)

The ACS 100 has the following LED alarm and fault indicators:

Red LED: off	Green LED: blinking
ABNORMAL CONDITION: <ul style="list-style-type: none"> • ACS 100 cannot fully follow control commands. • Blinking lasts 15 seconds. 	POSSIBLE CAUSES: <ul style="list-style-type: none"> • Acceleration or deceleration ramp is too fast in relation to load torque requirement • A short voltage interruption

Red LED: on	Green LED: on
ACTION: <ul style="list-style-type: none"> • Give a stop signal to reset fault. • Give a start signal to restart the drive. <p>NOTE: If the drive fails to start, check that the input voltage is within the tolerance range (200...240 V ±10 %).</p>	POSSIBLE CAUSES: <ul style="list-style-type: none"> • Transient overcurrent • Over-/undervoltage • Overtemperature <p>CHECK:</p> <ul style="list-style-type: none"> • supply line for phase loss or disturbances. • the drive for mechanical problems that might cause overcurrent. • that heat sink is clean.

Red LED: blinking	Green LED: on
ACTION: <ul style="list-style-type: none"> • Turn the power off. • Wait for the LEDs to turn off. • Turn the power back on. <p>Caution! This action may start the drive.</p>	POSSIBLE CAUSE: <ul style="list-style-type: none"> • Output earth fault • Short circuit <p>CHECK:</p> <ul style="list-style-type: none"> • the isolations in the motor circuit.

Note! Whenever the ACS 100 detects a fault condition, the fault relay activates. The motor will coast to stop and the ACS 100 will wait to be reset. If the fault still persists and no external cause has been identified, contact your ACS 100 supplier.

N Motor Overload Protection

If the motor current I_{out} exceeds I_2 of the ACS 100 for a prolonged period, the ACS 100 automatically protects the motor from overheating by tripping.

Trip time depends on the extent of the overload (I_{out} / I_2), the output frequency and f_{nom} . Times given apply to a "cold start".

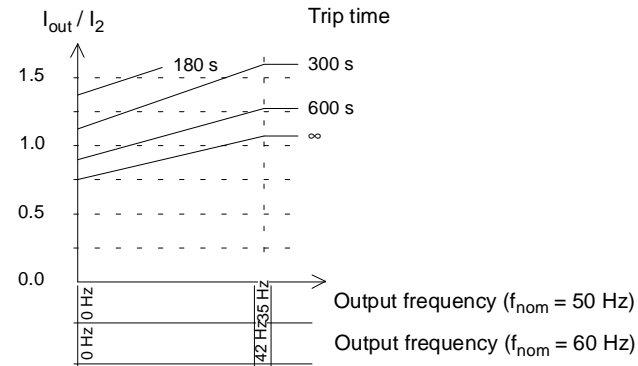

O Loadability of ACS 100

In the event of an output overload, the ACS 100 will trip.

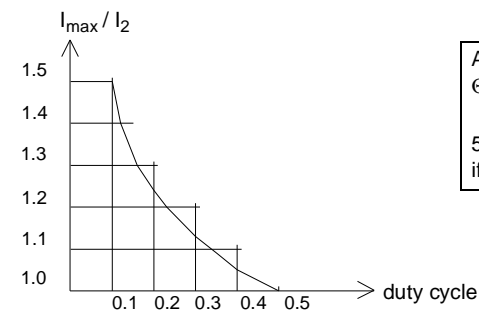
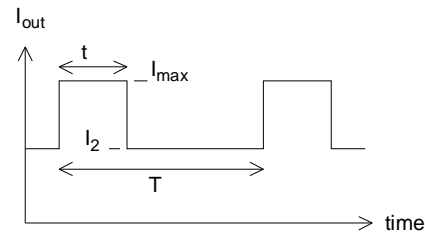

P Type Series and Technical Data

Nominal motor P _N	kW	0.37	0.55	0.75	1.1	1.5	2.2
1~ Input	ACS101-	K75-1	1K1-1	1K6-1	2K1-1	2K7-1	4K1-1
3~ Input	ACS103-	K75-1	1K1-1	1K6-1	2K1-1	2K7-1	4K1-1
Frame size		A	B		C		D
Nominal Ratings (See F, M)	Unit						
Input voltage U ₁	V	200 V-240 V ±10 % 50/60 Hz (ACS 101: 1~, ACS 103: 3~)					
Output current I ₂	A	2.2	3.0	4.3	5.9	7.0	9.0
Max. output current	A	3.3	4.5	6.5	8.9	10.5	13.5
Output voltage U ₂	V	0 - U ₁ 3~					
Input current I ₁ 1~	A	6.9	9.0	10.8	14.8	18.2	22.0
Input current I ₁ 3~	A	3.2	4.2	5.3	7.2	8.9	12.0
Switching frequency	kHz	4 (Standard) 8 (Low noise **)					
Protection limits	(See M)						
Overcurrent (peak)	A	7.1	9.7	13.8	19.0	23.5	34.5
Overvoltage: Running Start inhibit	V DC V DC	420 (corresponds to 295 V input) 390 (corresponds to 276 V input)					
Undervoltage: Running Start inhibit	V DC V DC	200 (corresponds to 142 V input) 230 (corresponds to 162 V input)					
Overtemperature	°C	90 (heat sink)			95 (heat sink)		
Max. wire sizes							
Power terminals	mm ²	4 single core					
Control terminals	mm ²	0.5 - 1.5 (AWG22...AWG16)					
Line fuse 1~ ACS101-	A	10	10	16	16	20	25
Line fuse 3~ ACS103-	A	6	6	6	10	10	16
Power losses							
Power circuit	W	13	19	27	39	48	70
Control circuit	W	14	16	17	18	19	20

**Low noise setting only available with optional control panel.
Derate ambient temperature to 30 °C or derate P_N and I₂ to 90 %.

Q Environment of Stationary Use

- Ambient temperature 0 - 40 °C
- Max ambient temperature 50 °C if P_N and I₂ derated to 80 %
- Installation altitude 0 - 1000 m
- Relative humidity less than 95 % (non-condensing)

The ACS 100 should be installed in clean and dry air, free from dripping water. The installation room must be locked or tool-openable.

R Product Conformity

The ACS 100 complies with the requirements of the European

- Low Voltage Directive 73/23/EEC with amendments
- EMC Directive 89/336/EEC with amendments

Corresponding declarations are available on request.



Note! See ACS 100 EMC instructions.

S Safety



Warning! Only a competent electrician may install the ACS 100.



Warning! Dangerous voltages are present when mains supply is connected. Wait at least 5 minutes after disconnecting the supply before removing the cover.



Warning! Even when the motor is stopped there are dangerous voltages present at Power Circuit terminals U₁, V₁, W₁ (L,N) and U₂, V₂, W₂ and U_{C+}, U_{C-}.



Warning! Even when the ACS 100 is powered down, there may be dangerous external voltages at relay terminals RO₁, RO₂, RO₃.



Warning! The ACS 100 is not a field repairable unit. Never attempt to repair a broken unit; contact the supplier to get the unit replaced.



Warning! The ACS 100 will start up automatically after an input voltage interruption, if the external run command is on.



Warning! The heat sink may reach high temperature (see P).

Note! For more technical information contact the supplier.

Accessories



ACS 100-PAN

Control panel for use with the ACS 100.

ACS 100-EXT

Extension cable kit for use with the control panel.

ACS 100-ENC

Enclosure to provide the ACS 100 with IP 65 (NEMA 4) protection.

ACS 100-FLT-

RFI input filter.

ACS 100-CHK-

Input/output choke.

ACS 100

User's Guide



ABB Industry Oy
P.O. Box 184
00381 Helsinki
FINLAND
Telephone +358-10-222 000
Telefax +358-10-222 2681

3AFY 61342427 R0125 REV B
EN

Effective: 1.6.1997

© 1997 ABB Industry Oy

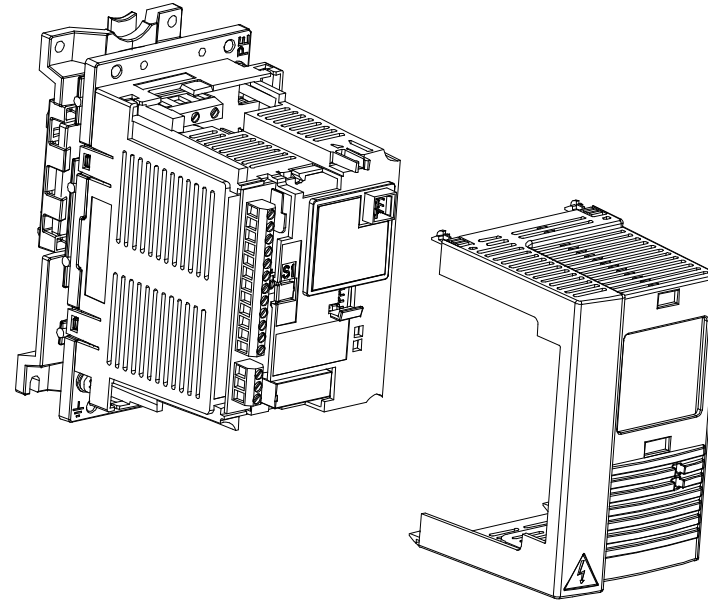
Subject to change without prior notice.

The ABB logo, consisting of the letters 'ABB' in a bold, stylized font where the letters are interconnected.